



型号 (1 代码 · 2 安装位置)
IAY30-C

■ 请按步骤 ①~② 选择型号和参数后进行订购。



型号区分: 代码 7 天发货

IAY30-C

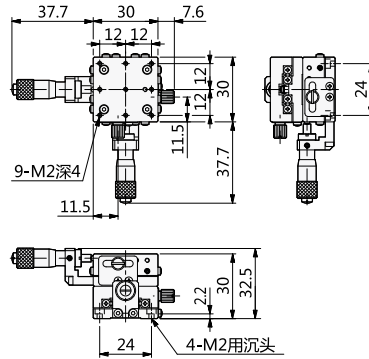

IAY30-L

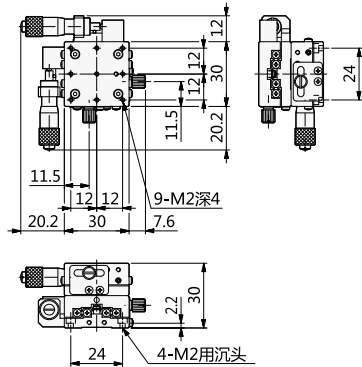
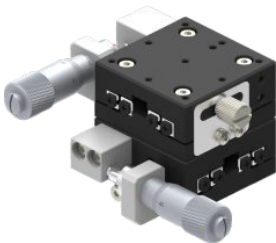

IAY30-R

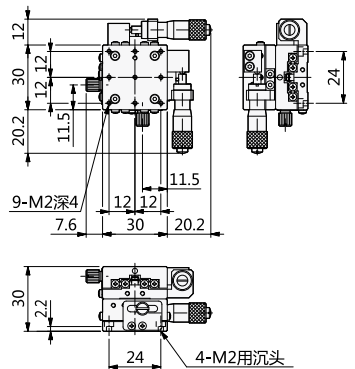
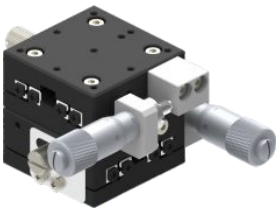

型号		移动方向	主体材质	驱动方式	台面大小	台面厚度	行程	负载	最小刻度	移动平行度	平行度	重量
① 代码	② 微分头安装位置											
IAY30	C	XY轴两个方向	铝合金 (黑色阳极)	微分头	30mm×30mm	30mm	±3mm	14.7N(1.5kgf)	0.01mm	≤0.05mm/6mm	0.04mm	0.12kg
	L											
	R											